

ANALYTICAL BALANCES (CAS & CAI Series)

0.0001g to 300g

CONTECH Analytical Balances incorporate advanced Electro Magnetic Force Compensation (EMFC) technology for offering unmatched accuracy and reliability, coupled with unique ADC circuit with inbuilt temperature compensation to offer a very high stability upto a resolution of 6 million counts. All adjustment parameters are programmable to take care of any minor mismatch of different sub assemblies & Balances are configured with these parameters.

Standard Features

Backlite LCD Display

Bi directional RS 232 interface

GSM function

Multiple Weighing Units

Percentage Weighing

Piece Counting

Fill Mode

1 set point - Indication when sample weight exceeds the set limit.

2 set points - Indication when the sample weight is between the lower & upper limits.

Accumulation

Storage of maximum 200 samples.

Multiple Printing Mode

External Calibration

Response Time:

User selectable - Slow / Normal /Fast.

Stability Band Width

Auto Zero Tracking

User selectable 0,1,2,3

Return to Zero Tracking

Variable: 0,1,2,3,4

Display Updation

Speed setting : Fast / Normal.

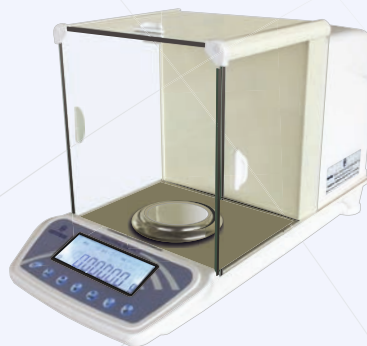

Customized, large, attractive LCD with Multiparameter display illuminated by white backlight



5" touch screen graphic display panel with keys configured for various applications

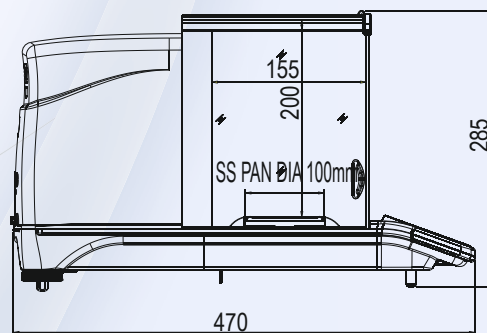
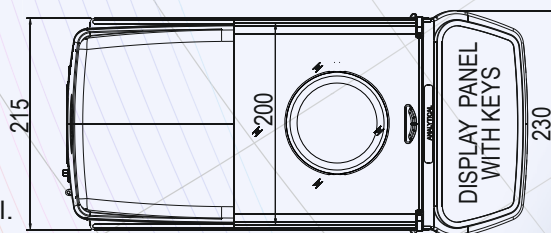

Optional Features (Extra charges applicable)

- ◆ 5" Touch screen graphic display.
- ◆ 21CFR Part 11 compliance (Optional only with TFT display)
- ◆ Motorized internal calibration.
- ◆ RS 232 to USB interface converter.
- ◆ GLP compliance/RTC.
- ◆ Density determination kit.
- ◆ Weigh below hook for density determination.
- ◆ Yarn count with temperature compensation.
- ◆ Denier measurement for silk & synthetic yarn.
- ◆ Anti vibration table.
- ◆ Standard weights / weight box.

Specifications :

Taring Range : Up to full capacity

Response time : 2-3 seconds

Power Req : 90-250V, 50/60Hz, 10 Watt

Operating Temperature : 10~45 deg C

Dimension (mm) : 470(L) x 230(W) x 285(H)

All Specifications and designs are subject to change for improvement.

Analytical Balances without motorized internal calibration

Models	CAS-54	CAS-84	CAS-164	CAS-234	CAS-304
Capacity	50g	80g	160g	230g	300g
Readability	0.0001g	0.0001g	0.0001g	0.0001g	0.0001g
Repeatability (+)	0.1mg	0.1mg	0.2mg	0.2mg	0.2mg
Linearity (+)	0.2mg	0.2mg	0.4mg	0.4mg	0.4mg
Pan Size(mm)	100	100	100	100	100

Analytical Balances with motorized internal calibration

Models	CAI-54	CAI-84	CAI-164	CAI-234	CAI-304
Capacity	50g	80g	160g	230g	300g
Readability	0.0001g	0.0001g	0.0001g	0.0001g	0.0001g
Repeatability (+)	0.1mg	0.1mg	0.2mg	0.2mg	0.2mg
Linearity (+)	0.2mg	0.2mg	0.4mg	0.4mg	0.4mg
Pan Size(mm)	100	100	100	100	100



Where innovation never stops....

301, Punit Indl. Premises, Turbhe Naka, Navi Mumbai - 400 705.

Tel. : +91 22 6139 3000 (100 lines)

E-mail : sales@contechindia.in

Website : www.contechindia.com



Plot No. EL-221 TTC Indl. Area, MIDC (Electronic Zone),
Mhape, Navi Mumbai - 400 710.

Impeccable Credentials

