

CRANE SCALES

500g to 10ton

(2, 3, 5, 10 ton)



CRANE SCALES with Wireless Indicator

Features :

- ♦ Wireless transmission maximum operating distance between the Scale and Indicator is 50 mtr.
- ♦ All specifications are same as standard crane scales (CCS) except there is no display on the scale and there is no remote keyboard.
- ♦ Power indication LED on the scale.
- ♦ Battery & charger for the loadcell & transmitter inside the scale.
- ♦ Weight display on the desktop indicator along with controls.
- ♦ RS-232 interface in the indicator (Optional).
- ♦ Indicator with optional battery backup.
- ♦ Date & time entry facility.
- ♦ Storage of weights in memory upto 100 samples.
- ♦ Display hold facility.

Common Specifications :

MODELS	CAPACITY	ACCURACY	DIMENSION				NET WT. (Kg)
			H	A	B	C	
CCS-2T500	2 ton	500g	465	56	65	25	12
CCS-3T1K	3 ton	1Kg	495	56	65	32	13
CCS-5T2K	5 ton	2Kg	595	72	90	36	18
CCS-10T5K	10 ton	5Kg	660	90	110	50	29

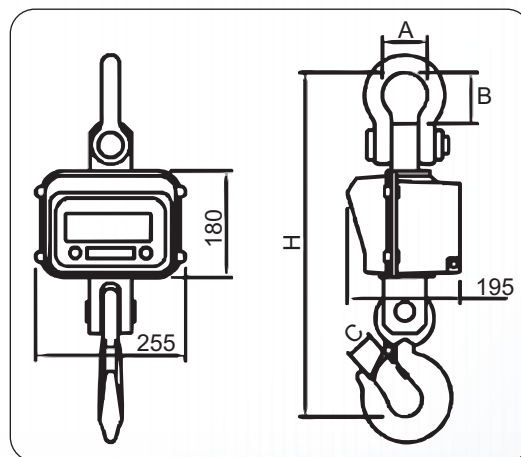

Taring Range : Up to full capacity

Response time : 5 seconds

Power Req : 90-250V, 50/60Hz, 10 Watt

Operating Temperature : 10 to 45 deg C

All Specifications and designs are subject to change for improvement.



CONTECH[®]
Instruments Ltd.
AN ISO 9001,14001 & OHSAS 18001 COMPANY

Where innovation never stops.....

301, Punit Indl. Premises, Turbhe Naka, Navi Mumbai - 400 705.

Tel. :+91 22 6139 3000 (100 lines)

Fax :+91 22 2761 8421

E-mail : info@contechindia.in / sales@contechindia.in

Website: www.contechindia.com



State Of The Art Manufacturing Plant