

CRANE SCALES with Heat Insulating Shield (CCS)

200g to 15ton

Features :

- ♦ Heavy duty aluminum diecast enclosure.
- ♦ Special construction for high temperature shielding.
- ♦ Minimum distance for normal operation is 2 mtr from a heat radiation source at 1500° C.
- ♦ 25 mm height LED display
- ♦ Maximum safety overload 200%.
- ♦ Inbuilt sealed maintenance free re-chargeable battery and battery charger (Optional)
- ♦ Infrared remote keypad, operating distance 5 mtr (Optional)
- ♦ RS-232 Interface (Optional)
- ♦ Multiple print options with Sr. No, Date, Time & Weight in horizontal / vertical mode.
- ♦ Date & Time entry facility.
- ♦ Multiple weighing units.
- ♦ Storage of weights in memory upto 100 samples.
- ♦ Power saving by switching off the display.
- ♦ Automatic zero tracking.
- ♦ Software linearity correction.
- ♦ Display hold facility.
- ♦ Gross & Net Weight function.



(1, 2, 3, 5, 10, 15 ton)

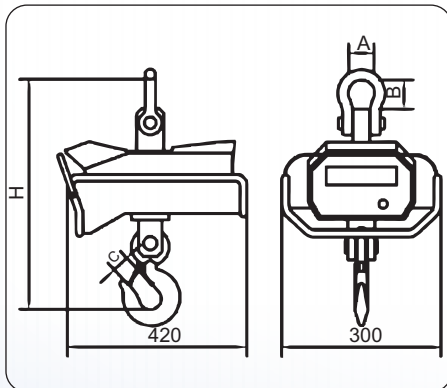

Common Specifications :

MODELS	CAPACITY	ACCURACY	DIMENSION				NET WT. (Kg)
			H	A	B	C	
CCS-1T200	1 ton	200g	465	56	65	25	26
CCS-2T500	2 ton	500g	490	56	65	32	30
CCS--3T1K	3 ton	1Kg	570	72	90	36	36
CCS-5T2K	5 ton	2Kg	640	90	110	50	42
CCS-10T5K	10 ton	5Kg	920	140	230	60	77
CCS-15T5K	15 ton	5Kg	980	140	230	70	85

Taring Range : Up to full capacity

Response time : 5 seconds

Power Req : 90-250V, 50/60Hz, 10 Watt

Operating Temperature : 10 to 45 deg C

All Specifications and designs are subject to change for improvement.