

WATER PROOF TABLE TOP SCALES

0.1g to 6Kg

Features :

- ◆ Electronics and loadcell totally protected from ingress of water.
- ◆ All exposed parts made of plastic & stainless steel.
- ◆ Incorporate high quality loadcells.
- ◆ Overload & shock protection for loadcells.

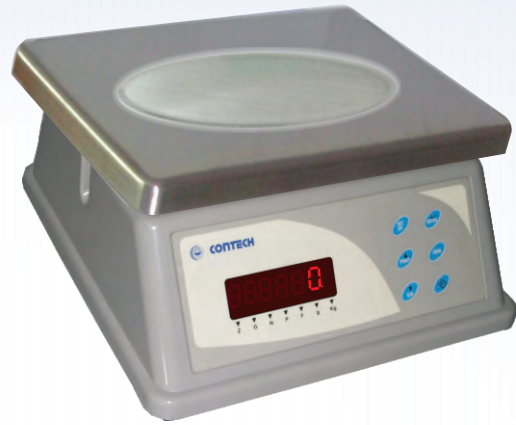

Specifications :

Models	CT-1001	CT-6K1
Capacity	1kg	6kg
Readability	0.1g	1g
Linearity (+/-)	0.2g	2g
Platform Size(mm)	220x280	220x280

Taring Range : Up to full capacity
 Response time : 3-5 secs
 Power Req : 90-250V, 50/60Hz, 10 Watt
 Operating Temperature : 10 to 45 deg C

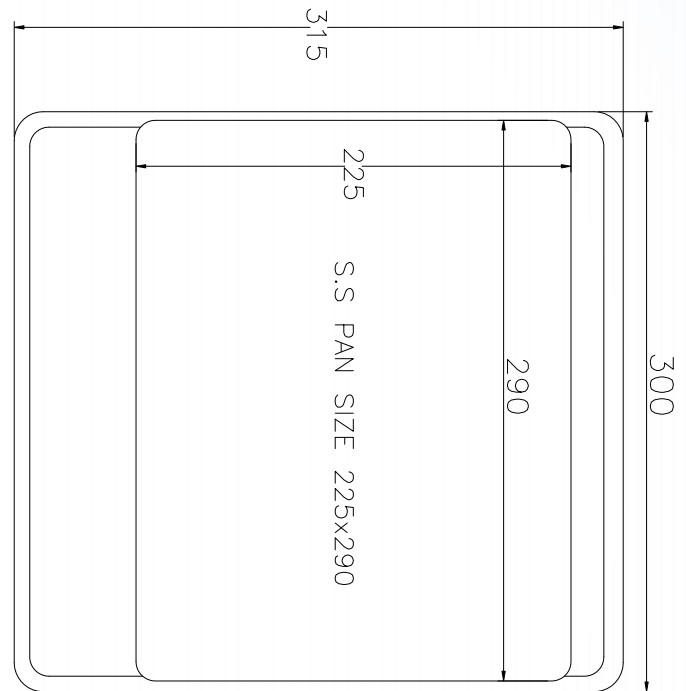

TOP VIEW

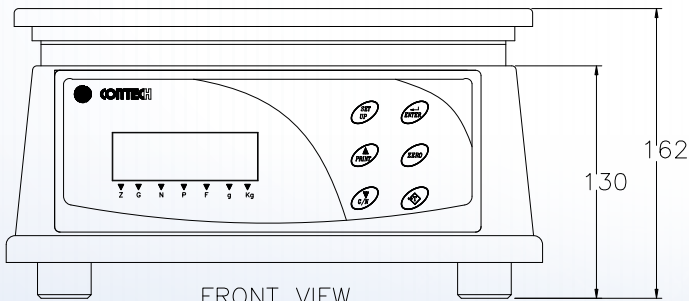

FRONT VIEW

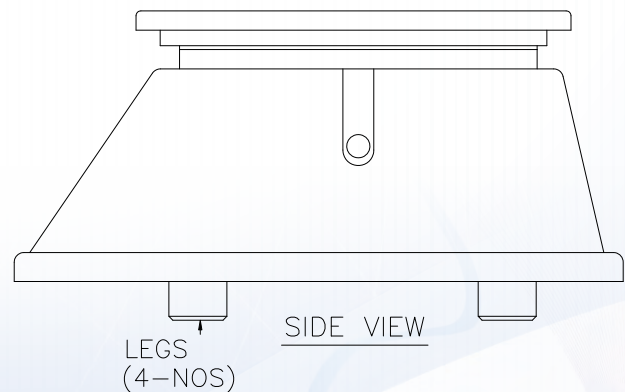

SIDE VIEW

All Specifications and designs are subject to change for improvement.