

ADULT SCALES

10g to 150Kg

Specifications :

Models	CP-150K10
Capacity	150kg
Readability	10g
Pan Size	300x300mm

- ◆ Rugged construction suitable for school, gym, sports.
- ◆ Stainless Steel Pan.
- ◆ LED Display.
- ◆ Battery backup.
- ◆ Storage of weights in memory upto 100 weights.
- ◆ Rs232 interface for computer & printer.
- ◆ Multiple weighing units Gram, Kilo gram, pound.

Taring Range : Up to full capacity
 Response time : 3-5 seconds
 Power Req : 90-250V, 50/60Hz, 10 Watt
 Operating Temperature : 10 to 45 deg C

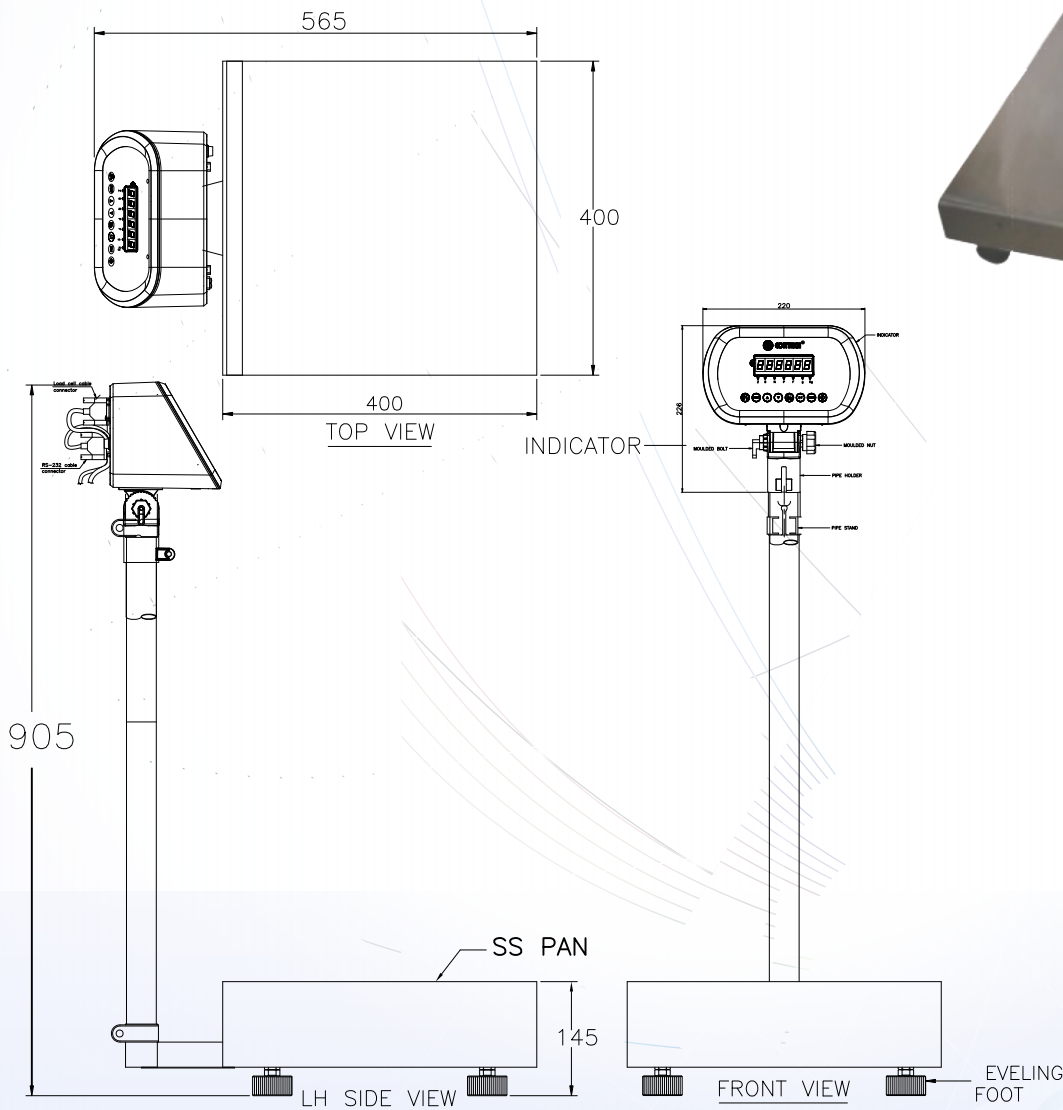

All Specifications and designs are subject to change for improvement.

