

WEIGHING INDICATORS

UNIVERSAL INDICATORS

Contech Platform Scales / Systems are offered with various types of Indicators for different working ambience and application.



- ◆ Selectable weighing capacity and least count through keyboard.
- ◆ High speed A/D conversion
- ◆ Full digital calibration through keyboard enabling easy replacement of Indicator in the system.
- ◆ 3 point linearity correction.
- ◆ Optional Battery Backup
- ◆ Bright LED Display
- ◆ RS-232 Interface (optional)
- ◆ Auxiliary Display (optional)
- ◆ USB Interface (optional)

Specifications :

Taring Range : Up to full capacity

Response time : 3-5 secs

Power Req : 90-250V, 50/60Hz, 10 Watt

Operating Temperature : 10 to 45 deg C

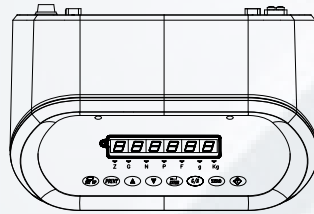

TOP VIEW

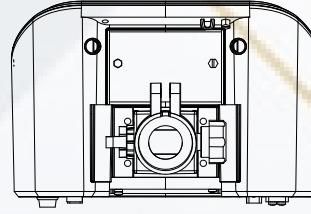

BOTTOM VIEW

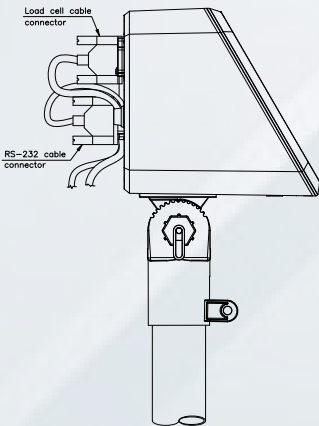

LH SIDE VIEW

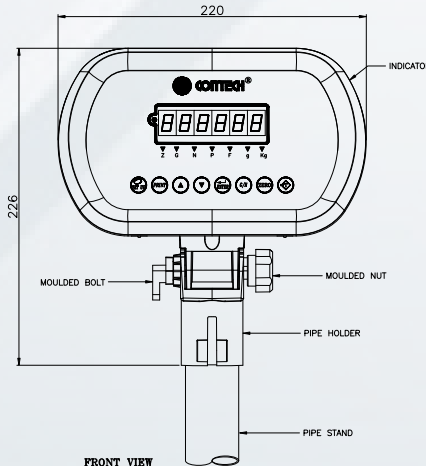

FRONT VIEW

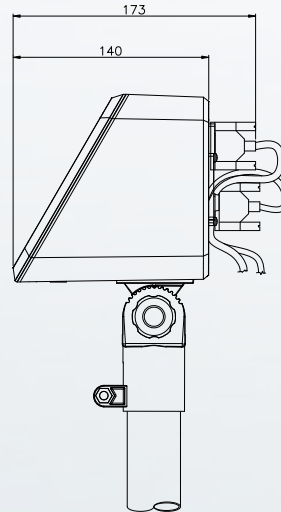

RH SIDE VIEW

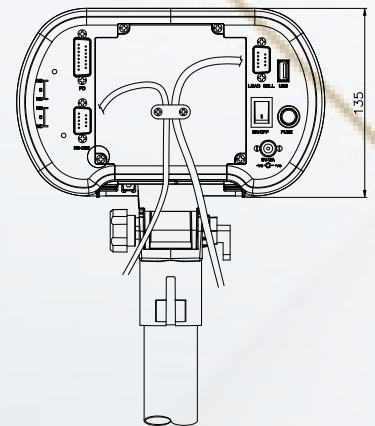

REAR SIDE VIEW

All Specifications and designs are subject to change for improvement.



301, Punit Indl. Premises, Turbhe Naka, Navi Mumbai - 400 705.

Tel. : +91 22 6139 3000 (100 lines)

E-mail : sales@contechindia.in

Website : www.contechindia.com

Impeccable Credentials



Plot No. EL-221 TTC Indl. Area, MIDC (Electronic Zone), Mhape, Navi Mumbai - 400 710.